



Date
Project
Fixture
Comments

GENERAL INFORMATION

The **Source Four LED** is the merging of the Source Four and Desire product lines. It offers the high-quality optics and control of a Source Four with the grace and powerful color control of Desire.

Source Four LED Lustr+ fixtures are based on the x7 Color System, utilizing six colors plus high-intensity white to achieve true, usable broad-spectrum color. Rich, vibrant colors as well as subtle theatrical tints are all possible with this color-changing fixture. Explore new opportunities by pairing with incandescent light from the original Source Four line of fixtures to provide maximum flexibility and range.

Source Four LED Daylight units are high-output non-variable white light fixtures with a 5600 K color temperature.

Source Four LED Tungsten models are non-variable white light fixtures with a 3000 K color temperature.

Lustr+, Daylight and Tungsten light engines work with all Source Four lens tubes to deliver a high-quality controllable beam of LED light. For the best results, we highly recommend that you use EDLT lens tubes. We also offer a special LED-only version of the 50° lens tube.

ORDERING INFORMATION

Source Four LED Light Engine with Shutter Barrel

(For use with fixed-field lens tubes only)

MODEL	DESCRIPTION	ETL PART NUMBER	CE PART NUMBER	
S4LEDLS	Source Four LED Lustr+ with shutter barrel, black	7460A1051	7460A1251	
S4LEDTS	Source Four LED Tungsten with shutter barrel, black	7460A1061	7460A1261	
S4LEDDS	Source Four LED Daylight with shutter barrel, black	7460A1071	7460A1271	

Source Four LED Light Engine Body

(For use with zoom lens tubes and retrofit of existing fixtures)

MODEL	DESCRIPTION	ETL PART NUMBER	CE PART NUMBER	
S4LEDL	Source Four LED Lustr+ – body only, black	7460A1050	7460A1250	
S4LEDT	Source Four LED Tungsten – body only, black	7460A1060	7460A1260	
S4LEDD	Source Four LED Daylight – body only, black	7460A1070	7460A1270	

Color options: -1 = White, -5 = Silver Gray/Custom Colors

Fixture ships with a soft-focus diffuser in the gobo holder and a five-foot powerCON® power input cable with connector of choice.

See page 4 for connector options.

Please note: Lens tubes to be ordered separately.



PRODUCT SPECIFICATIONS

Source

LED details	60 Lumileds LUXEON® Rebel LED
Max lumens	Lustr+: 4,862 Daylight: 8,157 Tungsten: 6,113
Lumens per watt	Lustr+: 37.7 Daylight: 55.8 Tungsten: 41.4
L70 rating (hours to 70% output)	50,000 hours

Color

Colors used	Lustr+: Red, Amber, Green, Cyan, Blue, Indigo, White Daylight: 5600 K Tungsten: 3200 K
Color temperature range	Lustr+: 2200–6500 K Daylight: 5600 K Tungsten: 3200 K
Calibrated array	Lustr+: Yes Daylight: No Tungsten: No
Red shift	Yes (Lustr+ only)

Optical

Beam angle range	Swappable lens tube between 5°–90°
Gate size	80 mm
Aperture size	6.25–14 in (depending on lens tube)
Pattern projection	Yes
Pattern size	A or B
Camera flicker control/Hz range	Yes: 900–25,000 Hz
Notes	Can be used with LED CYC and Fresnel adapters

Control

Input method	DMX512 via 5-pin XLR
Protocols	DMX and RDM
Modes (footprint)	See page 6
RDM configuration	Yes
UI type	LCD
Local control	Yes
Onboard presets	Yes
Onboard sequences	Yes
Onboard effects	No
Fixture-to-fixture control	Yes
Notes	15-bit virtual dimming engine

Electrical

Voltage range	100–240 VAC 50/60 Hz
Input method	Neutrik powerCON in and thru Requires power from non-dim source
Inrush	11 A at 120 V (First half-cycle) 15 A at 240 V (First half-cycle)
Fixtures per circuit	9 (15 A via power thru connector) 10 (R20 via module or similar relay)
Wattage typical	Lustr+: 129.9 W Daylight: 163.6 W Tungsten: 157.4 W
Current draw	Lustr+: 1.11 A at 120 V 0.58 A at 240 V Daylight: 1.39 A at 120 V 0.72 A at 240 V Tungsten: 1.35 A at 120 V 0.69 A at 240 V

Thermal

Ambient operating temp	0°–40° C (32°–104° F)
Fan (controllable)	Yes (yes)
Droop compensation	Yes
dB range	22.5 dBA average at 1 m
BTUs/hour	Lustr+: 440 Daylight: 498 Tungsten: 504

Physical

Materials	Die-cast, all metal housing
Color options	Black, white, silver, or custom color
Mounting options	Yoke, cyc floor stand (sold separately)
IP rating	IP20
Weight	With barrel: 8.3 kg (18.3 lb) Without barrel: 6.5 kg (14.3 lb)
Included accessories	Hanging yoke, 1.5 m power cable, soft-focus diffuser in an A-size gobo holder, gel frame, c-clamp*
Notes	- Positive locking double-clutch fixture body - Slot for glass or stainless steel patterns and soft focus diffuser - Wide accessory slot with sliding cover for motorized pattern device or iris

*not included with CE fixtures

Warranty

Fixture	5 years
LED array	10 years

Regulatory and Compliance

Approved regulatory standards	cETLus Listed Conforms to UL1573 Certified to C22.2 C22.#166 CE Compliant
-------------------------------	--

PRODUCT FEATURES

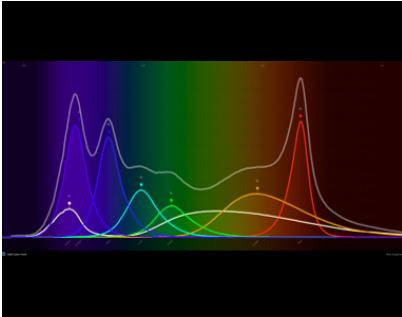

BROAD SPECTRUM COLOR
Interacts seamlessly with conventional sources.



MULTIPLE LED ARRAY OPTIONS
Available array options include Lustr+, Daylight, and Tungsten.



USER-FRIENDLY CONTROL INTERFACE
With multiple modes and fixture settings including color mixing as 'hue, saturation, brightness' or 'RGB.'

COLOR METRIC INFORMATION

SOURCE FOUR LED LUSTR+ 3200 K TM-30-18

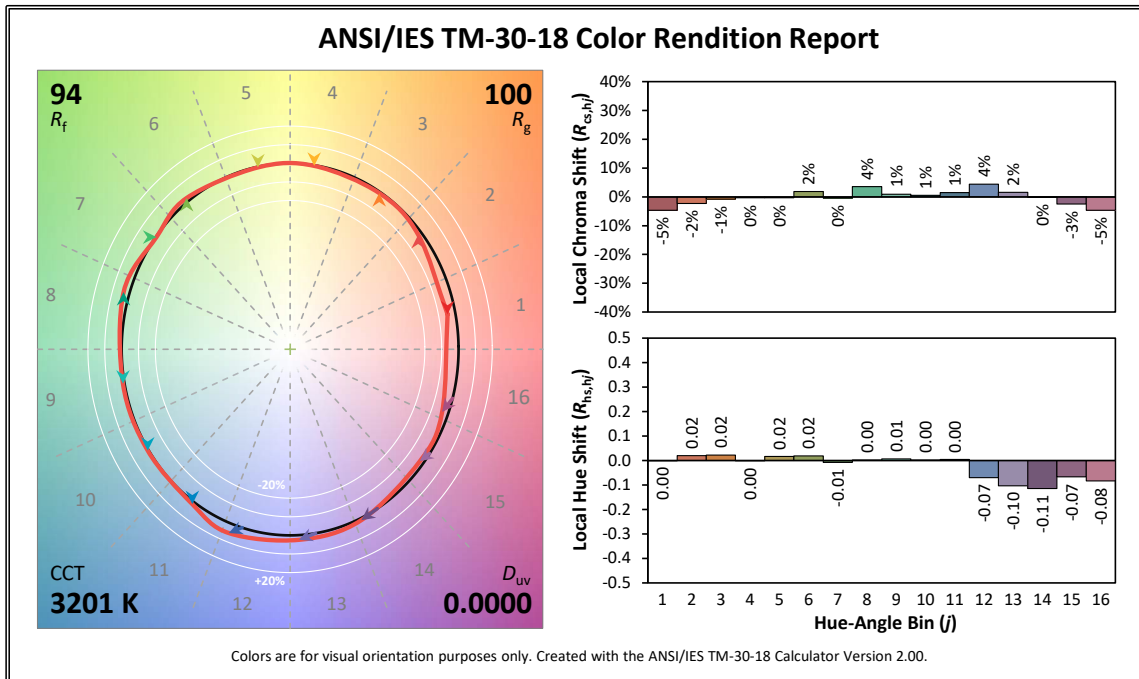

ETC utilizes a nationally recognized 3rd party lab for luminaire testing according to IES LM-84. See etconnect.com/About/News/ETC-Fixture-Ratings-and-Warranties-Extended.aspx.

All LED sources experience some lessening of light output and some color shift over time. LED output will vary with thermal conditions. In individual situations, LEDs will be used for different durations and levels. This can eventually lead to minor alterations in color performance, necessitating slight adjustments to presets, cues or programs.

COLOR METRIC INFORMATION

SOURCE FOUR LED LUSTR+ 4500 K TM-30-18

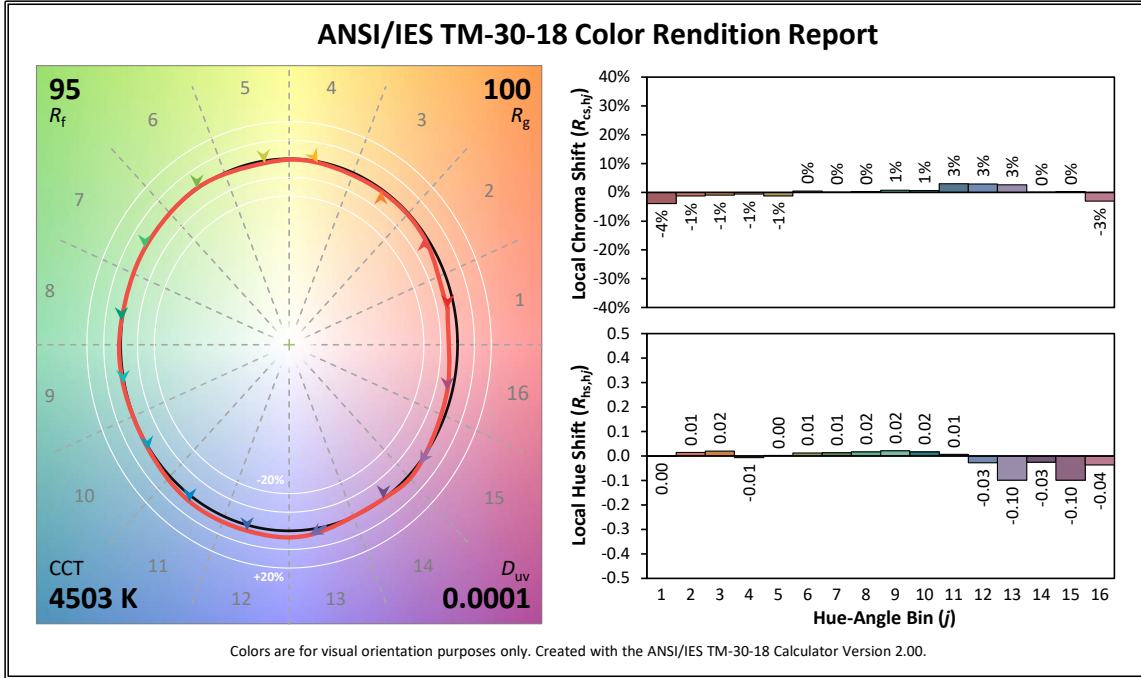

SOURCE FOUR LED LUSTR+ 5600 K TM-30-18

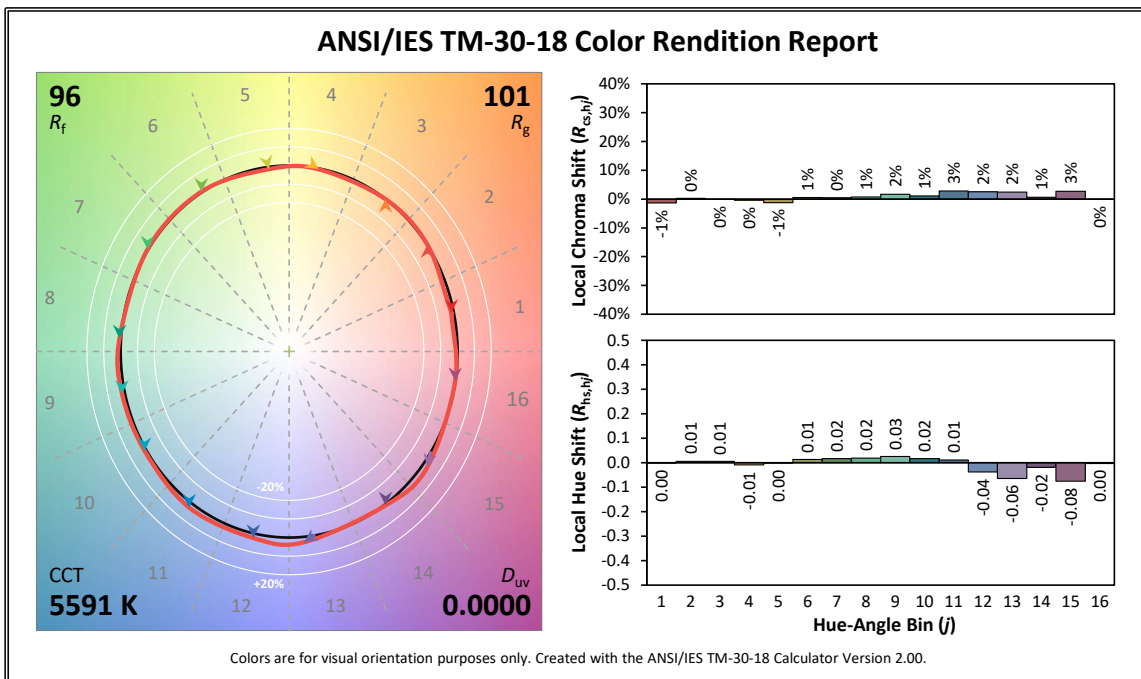

COLOR METRIC INFORMATION

SOURCE FOUR LED DAYLIGHT 5600 K TM-30-18

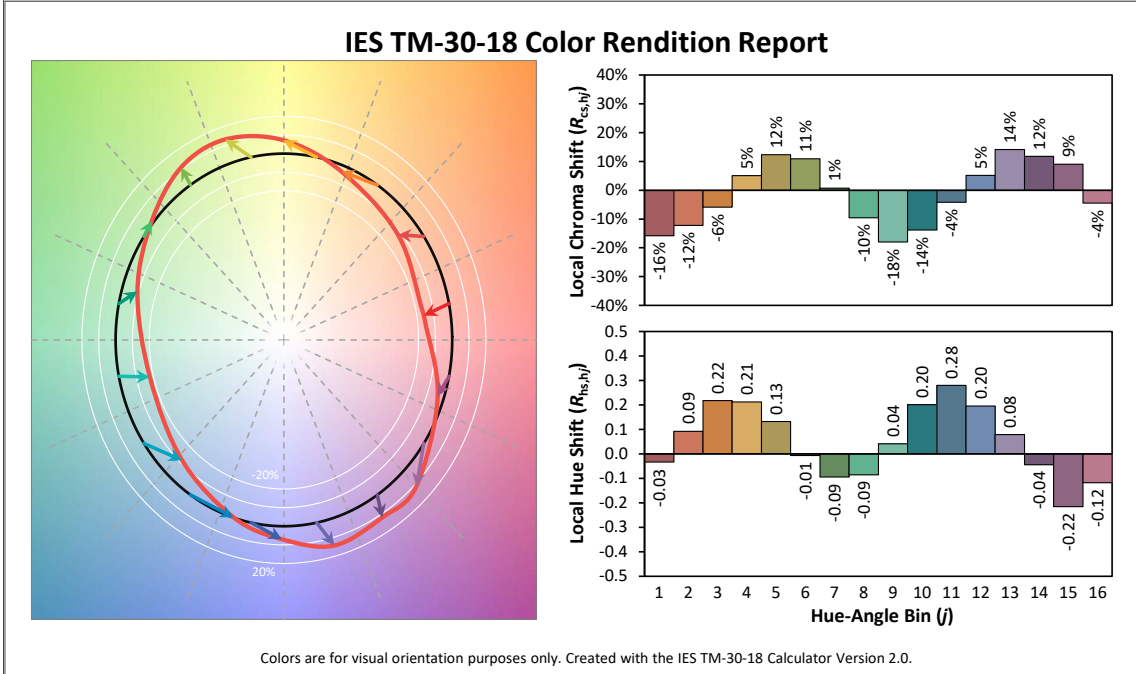

SOURCE FOUR LED TUNGSTEN 3000 K TM-30-18

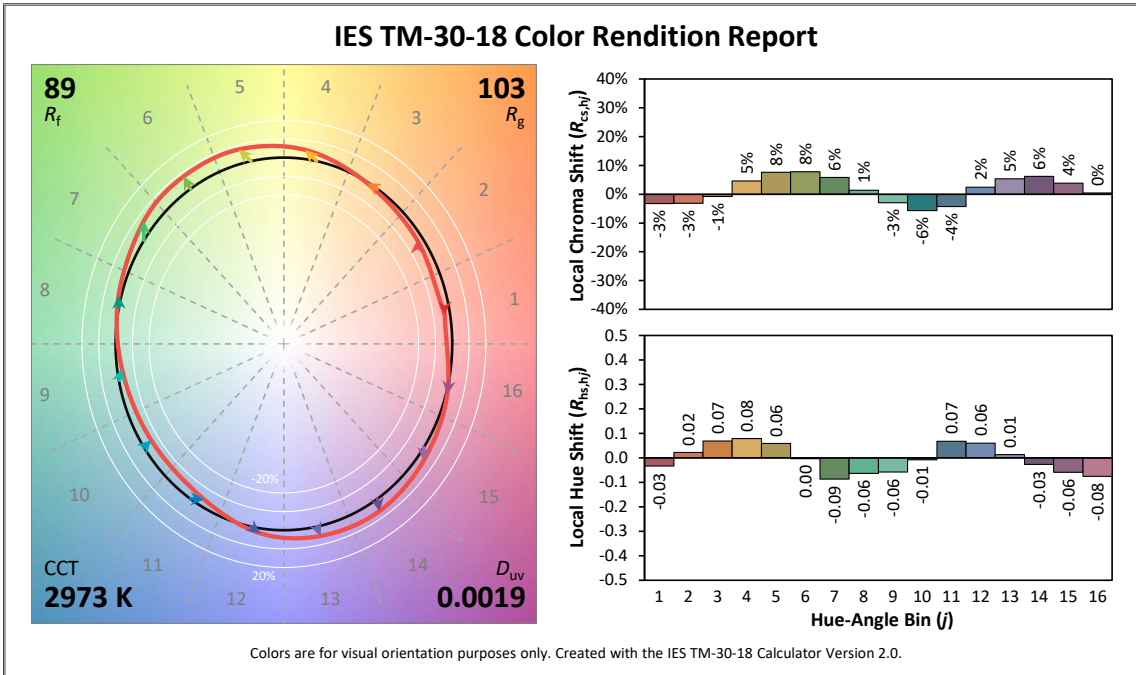

PREFERRED LENSING OPTIONS

(Lenses sold separately)

Fixed Beam Lenses

MODEL	DESCRIPTION	PART NUMBER
LED50LT	LED-specific 50° EDLT	7460A2008
LED50LT-1	LED-specific 50° EDLT (white)	7460A2008-1
436EDLT	36° EDLT	7060A2048
436EDLT-1	36° EDLT (white)	7060A2048-1
426EDLT	26° EDLT	7060A2047
426EDLT-1	26° EDLT (white)	7060A2047-1
419EDLT	19° EDLT	7060A2046
419EDLT-1	19° EDLT (white)	7060A2046-1
490LT	90°	7060A2052-K
490LT-1	90° (white)	7060A2052-1K
470LT	70°	7060A2051-K
470LT-1	70° (white)	7060A2051-1K
414LT	14°	7060A2050-K
414LT-1	14° (white)	7060A2050-1K
410LT	10°	7060A2001-K
410LT-1	10° (white)	7060A2001-1K
405LT	5°	7060A2000-K
405LT-1	5° (white)	7060A2000-1K

Zoom Lens Assemblies

Use with light-engine body models.

MODEL	DESCRIPTION	PART NUMBER
41530LT	Source Four 15–30° Zoom lens assembly	7060A2030-K
42550LT	Source Four 25–50° Zoom lens assembly	7060A2032-K

LED Adapters

MODEL	DESCRIPTION	PART NUMBER
S4LEDCYC	LED CYC Adapter	7460A2011
S4LEDFRES	LED Fresnel Adapter	7460A2016

ADDITIONAL ORDERING INFORMATION

Fixture Accessories

MODEL	DESCRIPTION	PART NUMBERS
400CC	C-Clamp (included)	7060A2009 (not CE)
400SC	Safety cable	7060A1022
400PH-A	Pattern holder (A size)	7060A1013
400PH-B	Pattern holder (B size)	7060A1014
400PH-G	Glass pattern holder	7060A1019
400RS	Drop-In Iris	7060A1012
400CF	Color frame (6.25 in)	7060A3043
407CF	7.5 in square color frame	7061A3007
400DN	Donut	7060A1015
400TH	Top hat	PSF1021
400HH	Half hat	PSF10216
DP5J-X	25 ft PowerCON to Edison input power cable with inline switch	7400B7030 (not CE)

Power Input Cables

Use information below to order 5 ft power input leads with factory-fitted connectors. CE fixtures ship with powerCON to bare end cable in the box.

MODEL	DESCRIPTION	PART NUMBERS
DPA-A	5 ft powerCON to parallel blade U-ground (Edison) connector	7410B7037-A
DPA-B	5 ft powerCON to 20 A two-pin and ground (stage pin) connector	7410B7037-B
DPA-C	5 ft powerCON to grounded 20 A twistlock connector	7410B7037-C
DPA-X	5 ft powerCON to bare-end power input lead	7410B7037-X

Power Thru Jumpers (not available for CE fixtures)

Note: Power thru jumpers connect to fixture's output (thru) connector to provide link to successive fixtures.

MODEL	DESCRIPTION	PART NUMBERS
DPJ-5	5 ft powerCON-to-powerCON fixture-to-fixture jumper	7410B7020
DPJ-10	10 ft powerCON-to-powerCON fixture-to-fixture jumper	7410B7010

Diffusers

MODEL	DESCRIPTION	PART NUMBERS
S4LED-SFD	Soft focus diffuser (included)	7460A4019
S4LED-SWD6	Smooth wash diffuser for 6.25 in gel frame slots	7460K1001
S4LED-SWD7	Smooth wash diffuser for 7.5" gel frame slots	7460K1002
S4LED-SWD12	Smooth wash diffuser for 10° lens tubes	7460K1003
S4LED-SWD14	Smooth wash diffuser for 5° lens tubes	7460K1004

The Soft Focus Diffuser fits into a standard A-Size pattern holder and delivers beautiful homogenized light when not in sharp focus. Also, use with patterns for dappled and soft-edge projections.

The Smooth Wash Diffuser is used when extra-smooth blending of multiple Source Four LED fixtures is required. The smooth wash diffuser is placed into the gel-frame slot of the lens tube.

CONTROL OPTIONS

User settings on Source Four LED fixtures allow multiple operational modes and settings for either console operation via DMX protocol or stand-alone operation. The expanded LCD display provides easy navigation to all possible settings and options. Some of the setting options are:

- Multiple DMX choices, ranging from a simple RGB profile – which effectively controls all seven LED colors via three channels – to nine-channel ‘direct’ color and intensity control
- Multiple dimming curve options
- Preset colors and sequences for stand-alone (no-console-required) operation
- White-point selection – white light and color behavior based on a specific color temperature white light, i.e., 3200 K, 5600 K, etc.
- Loss of data behavior options – instant off, hold last look for two minutes, etc.
- Output modes – three output options that offer the user a choice between maximum output and maximum consistency

See the user manual for a complete explanation of all of the control settings and options for the Source Four LED.

Quick Setups

To assist in managing the numerous control and fixture behavior choices, five combinations of operational settings are available to quickly get started. These settings are specifically created for different applications and are easily accessible at the fixture display. Each setting can then be modified as required to take advantage of all of the possible control features.

Setting Title	Profile	Description	Typical Features*
General	Direct	Factory default: For general-purpose use, including interior architectural applications	<ul style="list-style-type: none"> • Standard dimming curve • Regulated output for color consistency
Stage	HSI Plus 7 Enabled	Theatrical lighting: Duplicates the color and dimming behavior of tungsten stage lighting fixtures	<ul style="list-style-type: none"> • Incandescent dimming curve • Regulated output for color consistency • 3200 K white-point setting
XT Arch	HSI	Exterior architectural lighting: Provides a high degree of color consistency in high ambient temperature environments	<ul style="list-style-type: none"> • Standard dimming curve • Protected output • 3200 K white-point setting
High Impact	RGB	Event lighting: Enables quickest response, simple RGB control and strobe channel for maximum effect usage	<ul style="list-style-type: none"> • Quick dimming curve • Boost mode for maximum intensity • 5600 K white-point setting
Studio	Studio	Studio factory default: Enables three-parameter control of white light (intensity, white point, and tint) via DMX from console or from fixture display – no console required	<ul style="list-style-type: none"> • Linear dimming curve • Regulated output mode for color consistency

*See user manual for complete list of features for each Quick Setup

CONTROL OPTIONS

DMX Input Channel Profiles

DMX Profile	DMX Channels	Channel Assignments	Notes
Direct	10	1 – Red 2 – White 3 – Amber 4 – Green 5 – Cyan 6 – Blue 7 – Indigo 8 – Intensity 9 – Strobe 10 – Fan Control	Direct control of each individual color with a separate master intensity channel. Color calibration of LEDs is not active in this mode. This profile will produce additive color crossfades.
HSI	6	1 – Hue (coarse) 2 – Hue (fine) 3 – Saturation 4 – Intensity 5 – Strobe 6 – Fan Control	High-resolution hue (two channels), saturation, and intensity control. HSI mode will produce color crossfades around the color space.
HSIC	7	1 – Hue (coarse) 2 – Hue (fine) 3 – Saturation 4 – Intensity 5 – Strobe 6 – Fan Control 7 – Color Point (CCT)	High-resolution hue, saturation and intensity control as above, with the addition of a color-point channel to adjust the color temperature of the fixture in both white light and color. Color crossfade performance is the same as HSI.
RGB	6 (Ch. 4 not used)	1 – Red 2 – Green 3 – Blue 4 – n/a 5 – Strobe 6 – Fan Control	Effectively addresses all seven colors via three channels of control. RGB profile will produce additive color crossfades.
Studio	6 (Ch. 4 not used)	1 – Intensity 2 – Color Point (CCT) 3 – Tint 4 – n/a 5 – Strobe 6 – Fan Control	Controls fixture as a white-light unit. If no DMX (i.e., console input) is present, fixture can be adjusted for these three parameters on the UI at the back of the unit.
Additional profile options			
Plus 7		Seven additional color-control channels are available in RGB, HSI, and HSIC input profile settings. For example, HSI with ‘Plus 7’ enabled becomes a 15-channel profile:	
		1 – Hue (coarse) 2 – Hue (fine) 3 – Saturation 4 – Intensity 5 – Strobe 6 – Fan Control 7 – n/a 8 – Plus 7 Control on/off 9 – Red 10 – White 11 – Amber 12 – Green 13 – Cyan 14 – Blue 15 – Indigo	<p>The desired color and intensity is achieved by using the HSI or RGB channels</p> <p>Placing channel eight at a value over 51% gives the fixture a 15-channel profile.</p> <p>Channels 9-15 represent the native colors of the fixture and allow the operator to adjust individual color channels to fine-tune the color output.</p>
Strobe		Variable strobe control: 0% is no strobe. The fixture output will strobe more rapidly as the strobe channel value approaches 100%.	

CONTROL OPTIONS

Daylight and Tungsten only

Quick Setups

Setting Title	Profile	Description	Typical Features
Studio	Studio	Enables control of intensity from luminaire UI; no console required	<ul style="list-style-type: none"> • Linear dimming curve • Regulated output for intensity stability
Single Channel	Direct	For general purpose architectural use	<ul style="list-style-type: none"> • Standard dimming curve • Regulated output for color consistency
Stage	Direct	Matches conventional luminaire performance	<ul style="list-style-type: none"> • Incandescent dimming curve • Regulated output

DMX Input Channel Profiles

DMX Profile	DMX Channels	Channel Assignments	Notes
Studio	3	1 – Intensity 2 – Strobe 3 – Fan Control	You can modify parameters from the luminaire's user interface. No console required.
Direct	3	1 – Intensity 2 – Strobe 3 – Fan Control	

PHOTOMETRY

The Source Four LED Photometry Guide and complete IES photometry data files may be downloaded from the ETC website. Go to etconnect.com

PHYSICAL

Source Four LED Weights and Dimensions

	WEIGHT*		SHIPPING WEIGHT	
	lb	kg	lb	kg
With Barrel	18.3	8.3	28	12.7
Without Barrel	14.3	6.5	23	10.4

* Does not include mounting hardware or lens tube

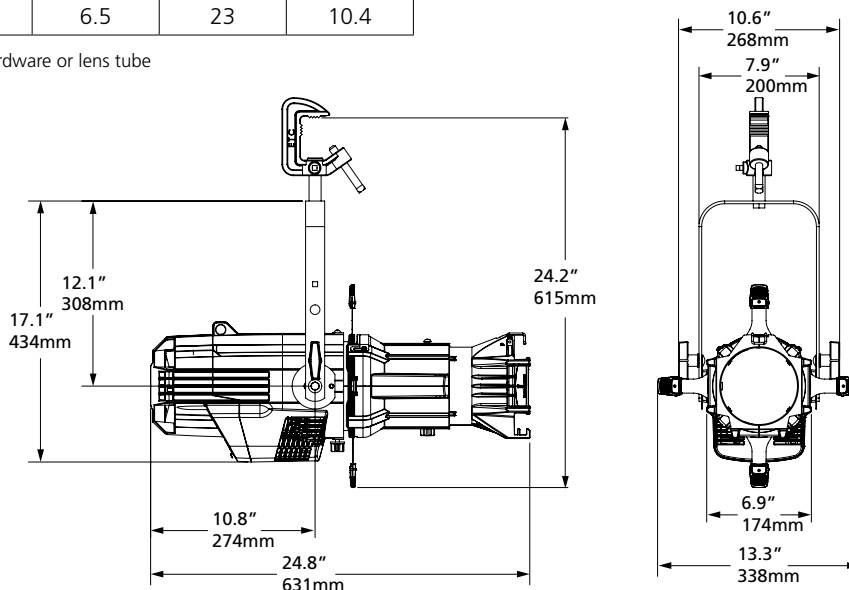

Corporate Headquarters • Middleton, WI USA

Global Offices • London, UK • Rome, IT • Holzkirchen, DE • Paris, FR • Hong Kong • Dubai, UAE • Singapore • New York, NY • Orlando, FL • Los Angeles, CA

Copyright©2020 ETC. All Rights Reserved. All product information and specifications subject to change. Rev A 1/20

Trademark and patent info: etconnect.com/IP